

REPORT SERVICES POLYTESTS INC.

695-B rue Gaudette

St-Jean-sur-Richelieu, QC, J3B 7S7

REPORT No. P-1534-E

Evaluation of Railing system
Model: Frameless Glass Railing System

Client:
Glassupply.com
80 rue de Normandie, Repentigny, J6A 4W2

Attention: Alexis Piette

GENERAL: This report presents the results of load tests performed on samples provided by client Glassupply.com; all tests were carried out in POLYTESTS laboratory. Results only apply to samples tested. The results apply only to the product tested. This report may be reproduced in part, except with the permission of POLYTESTS Services Inc.

TABLE OF CONTENT

1	RESULTS.....	1
1.1	GENERAL	1
1.2	PRODUCT LINE AND TEST SAMPLES	1
2	TEST PROGRAM.....	2
2.1	RESULTS	2
2.2	TEST DESCRIPTION	3
3	CONCLUSION	4

Appendix A

Appendix B

Appendix C

1 Results

1.1 General

This report covers the load tests performed on representative samples of guard railings in accordance with the requirements of the National Building Code (NBC) 2015 and the Ontario Building Code (OBC) 2012 (9.8.8.2). Evaluation period was done in July 2021

1.2 Product line and test samples

Several specimens of each system of 63 inches long model Frameless glass railing system from Glassupply.com were delivered to Services Polytests for testing in July 2021. The testing was done by Alain Lefebvre from POLYTESTS

General:

Material:	Tempered glass 12mm CAN/CGSB-12.1-M
Model tested:	Frameless Glass Railing System 63 X 42
Model covered:	Frameless Glass Railing System 63 X 42 / and shorter until 16 inches.
Overall Dimension:	1.60 m (63in) long x 1.06 m (42in) high

Product description:

Hand rail:	none
Glass clip:	44.45mm (1.75in) de high X 95.25mm (3.75in) long
Glass:	1.6 m (63in) long x 981.07 mm (38.625in) wide x 12 mm (0.472in) thick
Glass panel support:	support base 98.4mm (3.875in) X 98.4mm (3.875in) x 158.75mm (6.75po) de height. Base plate 98.4mm (3.875in) X 98.4mm (3.875in)
Floor fixations:	Wood (Appendix B): four Lag bolt 3/8 in Diameter – 6 in long Concrete (minimum 25 Mpa): Six concrete Hilti anchor 1/4 in. X 2 1/4 in. long

2 Test program

Test # 1 The guardrail system shall be designed to resist a horizontal load of 0.75 kN/m or a concentrated load of 1.0 kN applied at any point along the top rail, whichever governs (NBCC 9.8.8.2). For this system, both the distributed 0.75 kN/m and concentrated 1.0 kN loads were applied, with the concentrated load applied at the juncture between the rail and post and at any point of the rail.

Test # 2 The guardrail system shall be designed to resist a 1.5 Kn/m load applied vertically (force directed downward) at the top of the guard (NBCC 9.8.8.2).

Test # 3 Individual elements within the guard, including glass component, must be designed to resist a concentrated load of 0.5kN at any point in the element (NBCC 9.8.8.2). The force was applied at the midpoint of the glass component with plywood of 300mm X 300 mm for installation guard serving not more than 2 dwelling units.

2.1 Results

Loading description	Specified load	1,5 X Factored for live load required	1.1 X Factored Minimum design load required	Test Results (pass or fail)
1.1 Uniformly distributed load applied in the horizontal direction (on two 42 inches length sections)	0,75 KN/m	1,125 KN/m	1,24 KN/m	Pass
1.2 Uniformly distributed load applied in the horizontal direction (on two 63 inches length)	0,50 KN/m	0,75 KN/m	0,825 KN/m	Pass
1.3 Concentrated load applied at any point of the rail in a horizontal direction	1,0 KN	1,5 KN	1,65 KN	Pass
1.4 Concentrated load applied at end of the rail in horizontal direction	1,0 KN	1,5 KN	1.65 KN	Pass
2. Uniformly distributed load applied in the vertical direction	1,5 KN/m	2,25 KN/m	2.48 KN/m	Pass
3. For guards not more than 2 dwelling applied over a maximum width of 300 mm and height of 300 mm	0,5 KN	0,75KN	0.825 KN	Pass

Note: Safety factors of 1.65 have been applied to all load during test series. Tests have been done on three samples.

2.2 Test Description

Loading time: between 15 sec to 30 sec

Load holding time: 1 min minimum

Sample evaluation: Following each test, sample was inspected for signs of failure, component displacement or cracking of structural components that could impair the safety of the product. The product shall remain safe for its intended use after each test. A serviceability testing load is done on each sample following maximum load to ensure the integrity of the assembly.

- Loading 1.1: Uniformly distributed load applied in the horizontal direction for outdoor installation that can serve more than 2 dwellings (on two 42in length sections)
- Loading 1.1: Uniformly distributed load applied in the horizontal direction for outdoor installation deserving less than 2 dwellings (on two 63in length sections)
- Loading 1.3: Concentrated load applied at any point of the rail in a horizontal direction
- Loading 1.4: Concentrated load applied at end of the rail in horizontal direction
- Loading 2: Uniformly distributed load applied in the vertical direction
- Loading 3: For guards not more than 2 dwelling applied over a maximum width of 300 mm and height of 300 mm on the glass component.

3 Conclusion

Based on the results obtained following testing, Glassupply.com model: Frameless glass railing system meets the factored design load performance requirements as outline in the 2015 National building code of Canada (NBCC); 2012 Ontario Building code (OBC) for use within dwelling and as exterior guards for 63in lengths or less. and for an outdoor installation that can serve more than 2 dwellings for lengths of 42in lengths and less.

Tested by:
Alain Lefebvre



Reported by:
Danick Power, Eng.



Review by:
Gaétan Piedalue, Eng.



Appendix A
Testing details and pictures

1.1 uniformly distributed horizontal load



1.2 Concentrated load applied midpoint at the highest point in horizontal direction

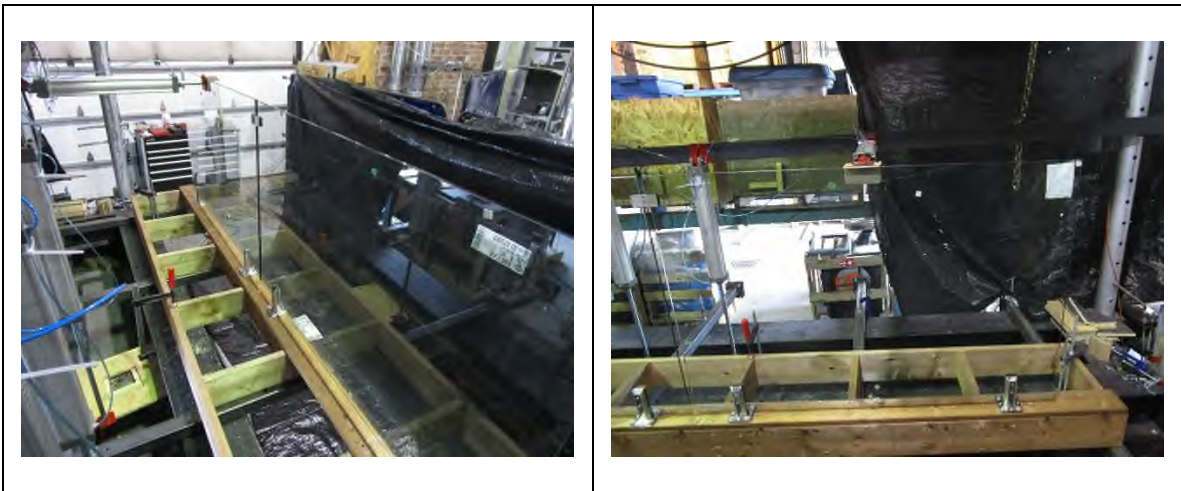

1.3 Concentrated load applied end rail at the highest point in horizontal direction





2. uniformly distributed vertical load



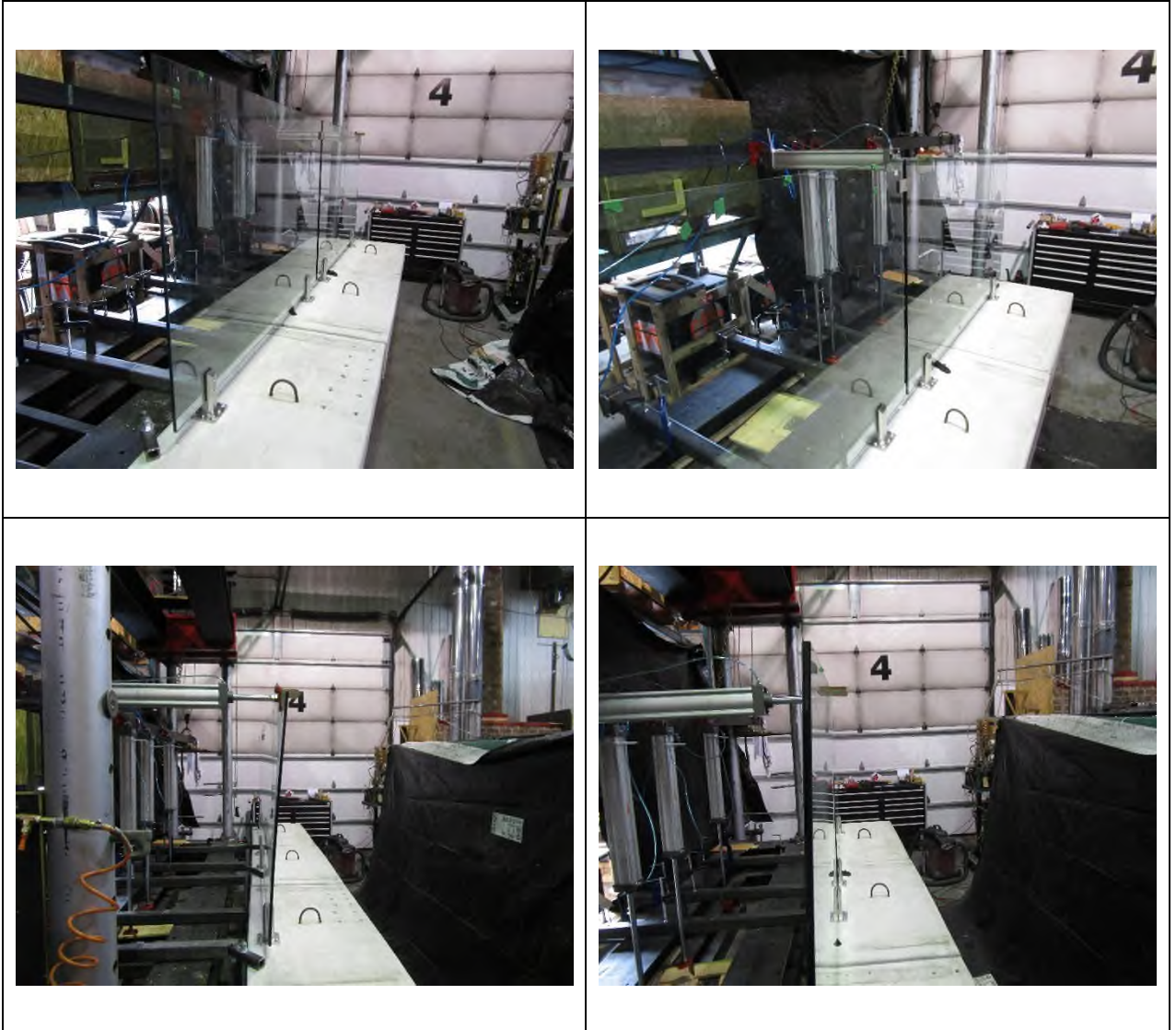

3. Concrete installation testing 25Mpa.

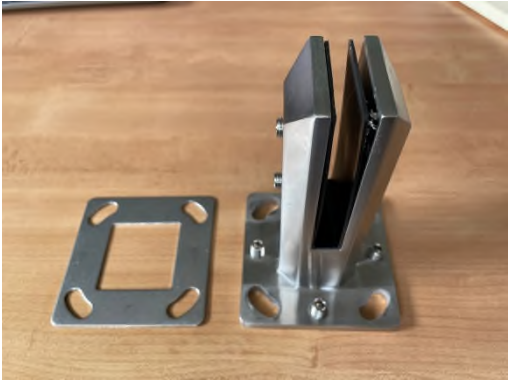

Anchors description

Wood (see assembly in appendix B)	Concrete (minimum 25 Mpa)
4 X Lag bolt 3/8 – 6in long	4 X Hilti Anchor 1/4in. X 3in long with washer
	

Glass support	Glass support
	

Appendix B
Distributed Drawings
(5 pages)

Wood surface installation end of joists

Top view

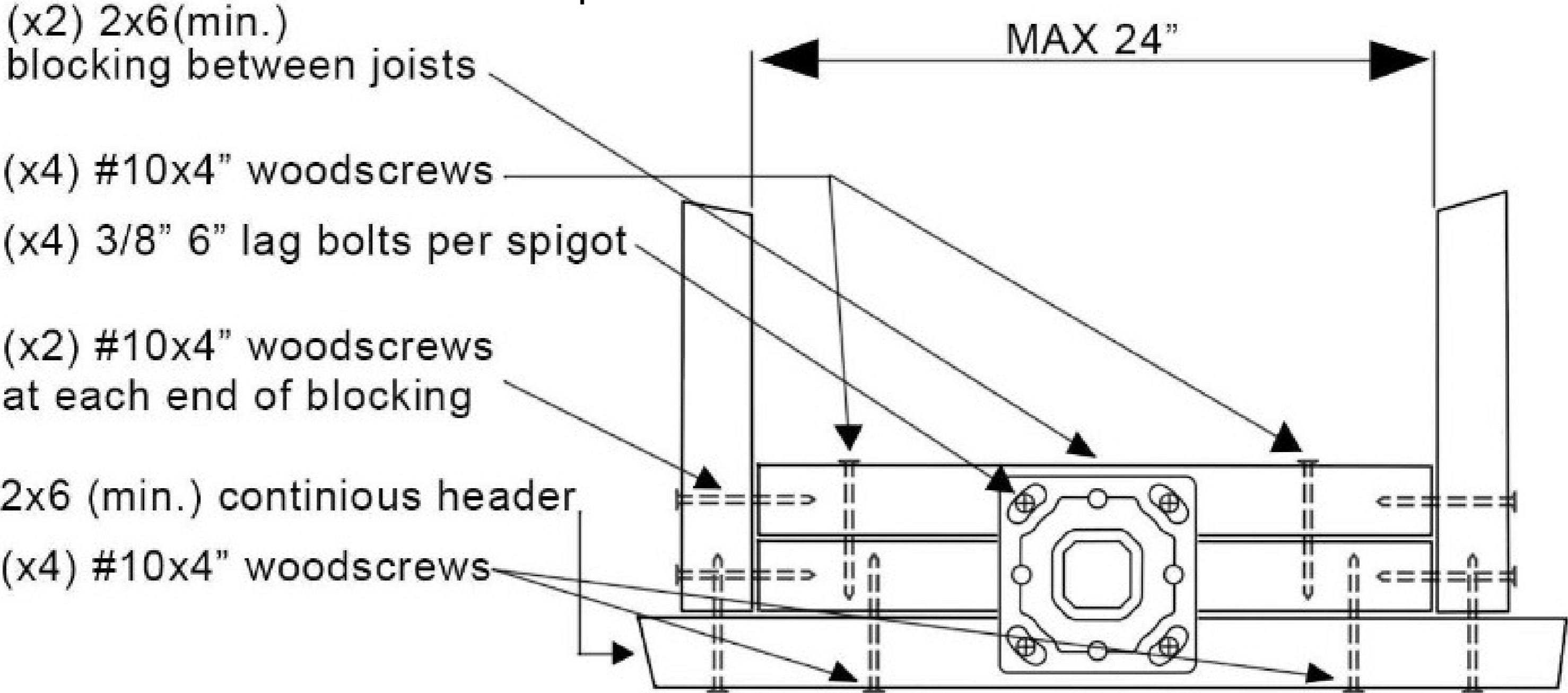

Wood surface installation cont.
end of joists

Side view

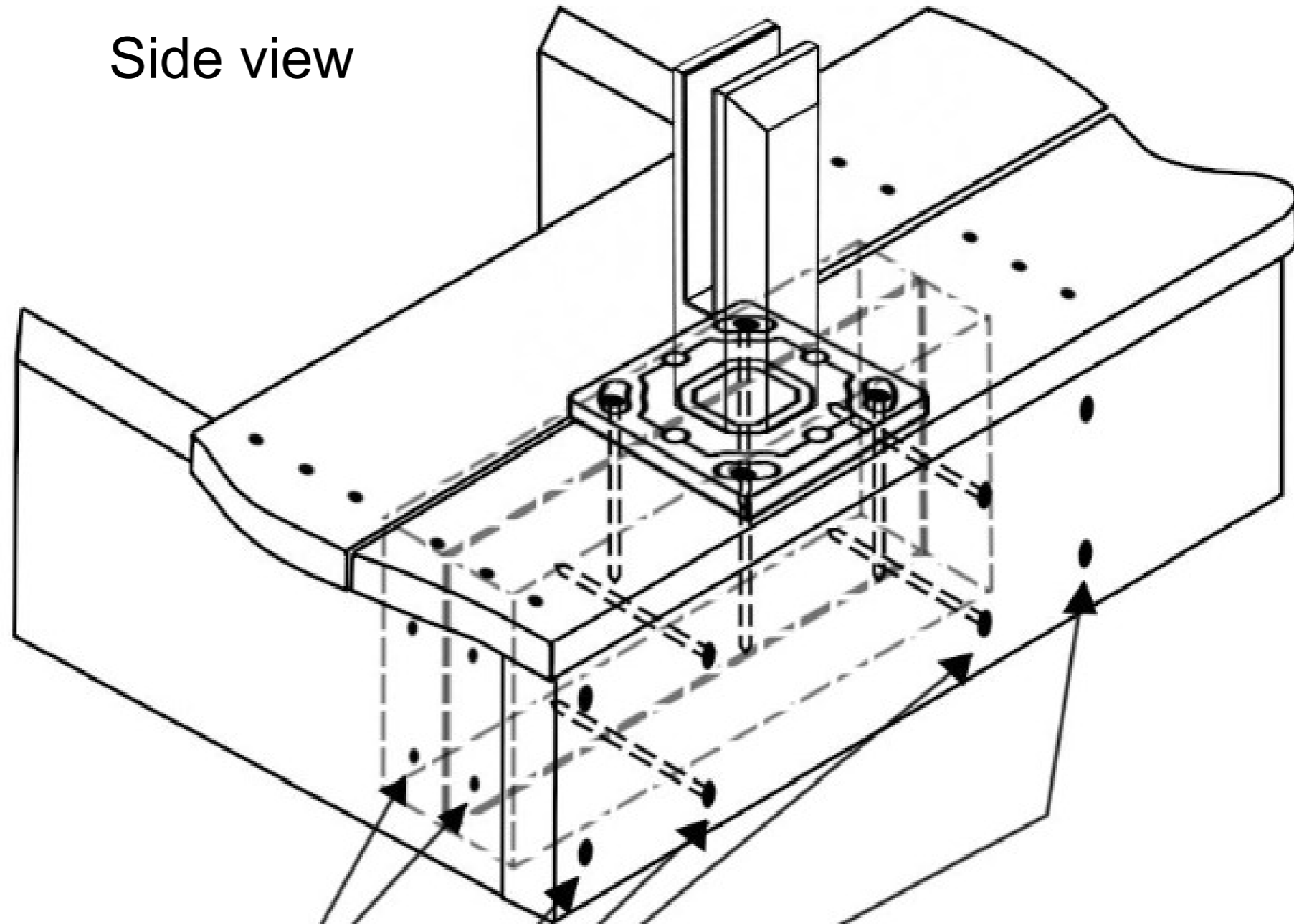

(x4) #10x4" woodscrews

(x8) #10x4" woodscrews

Concrete Surface installation

1/4"x3" Hilti, KH-EZ
(Installed as per manufacturer's
Instructions)

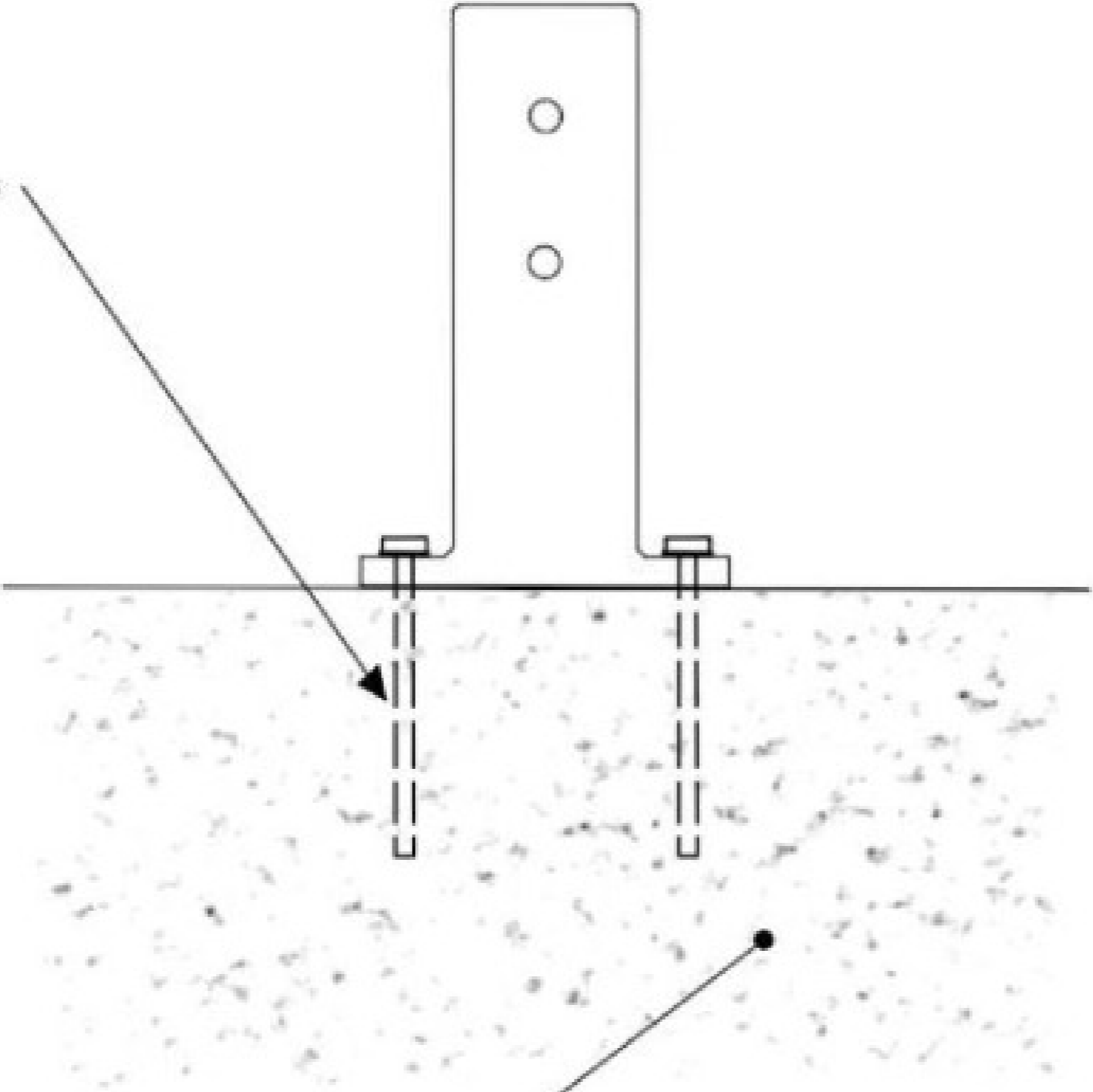

Minimum 25 MPA(3625 PSI) Concrete

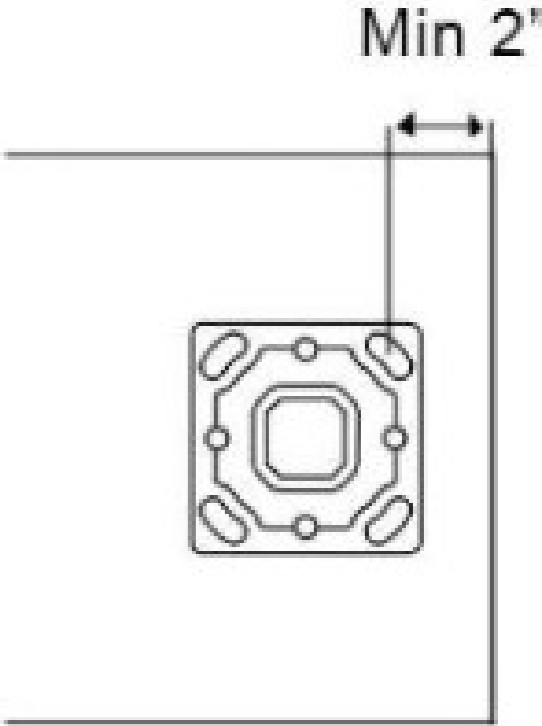

Residential application

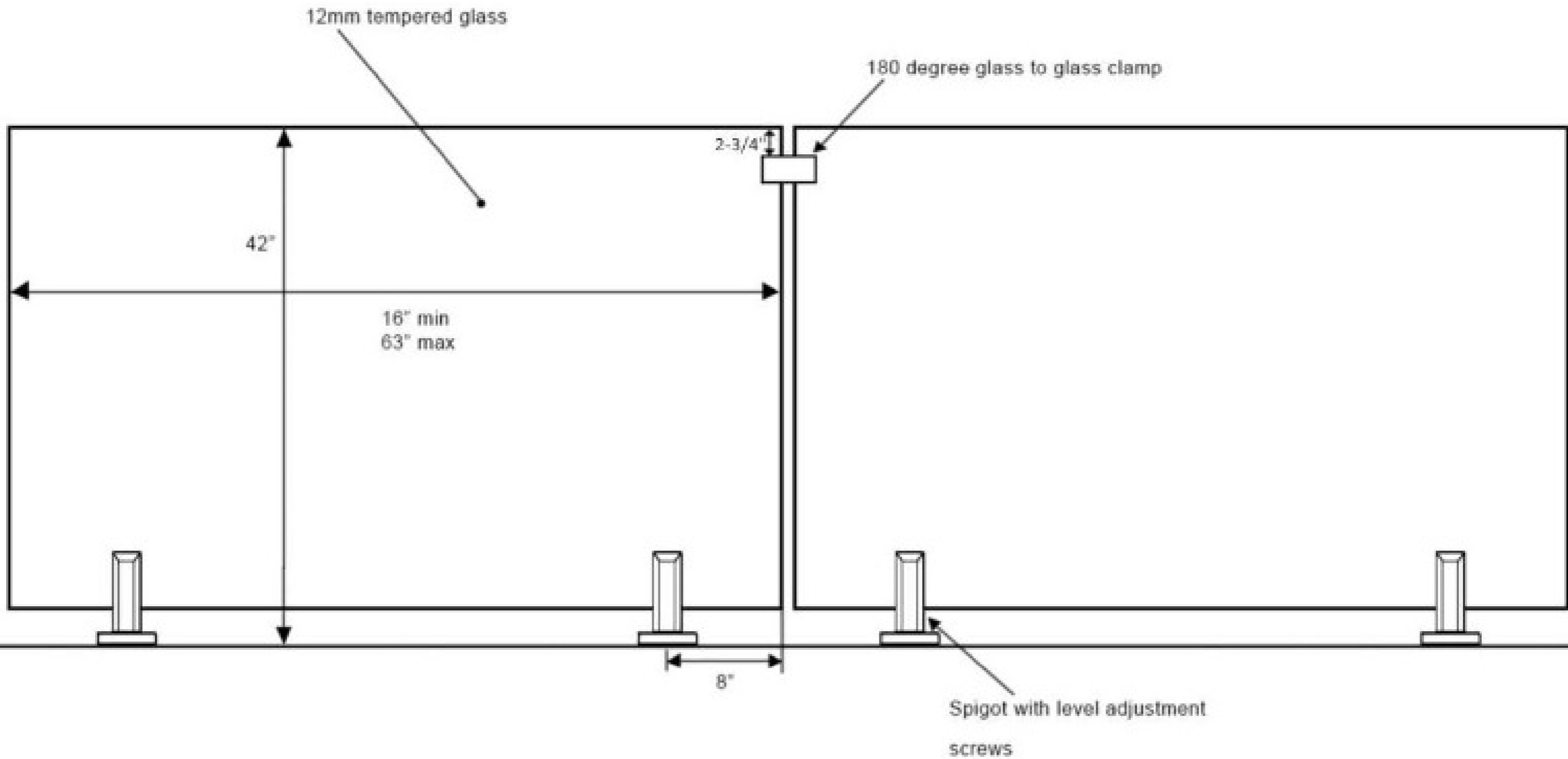

Commercial application

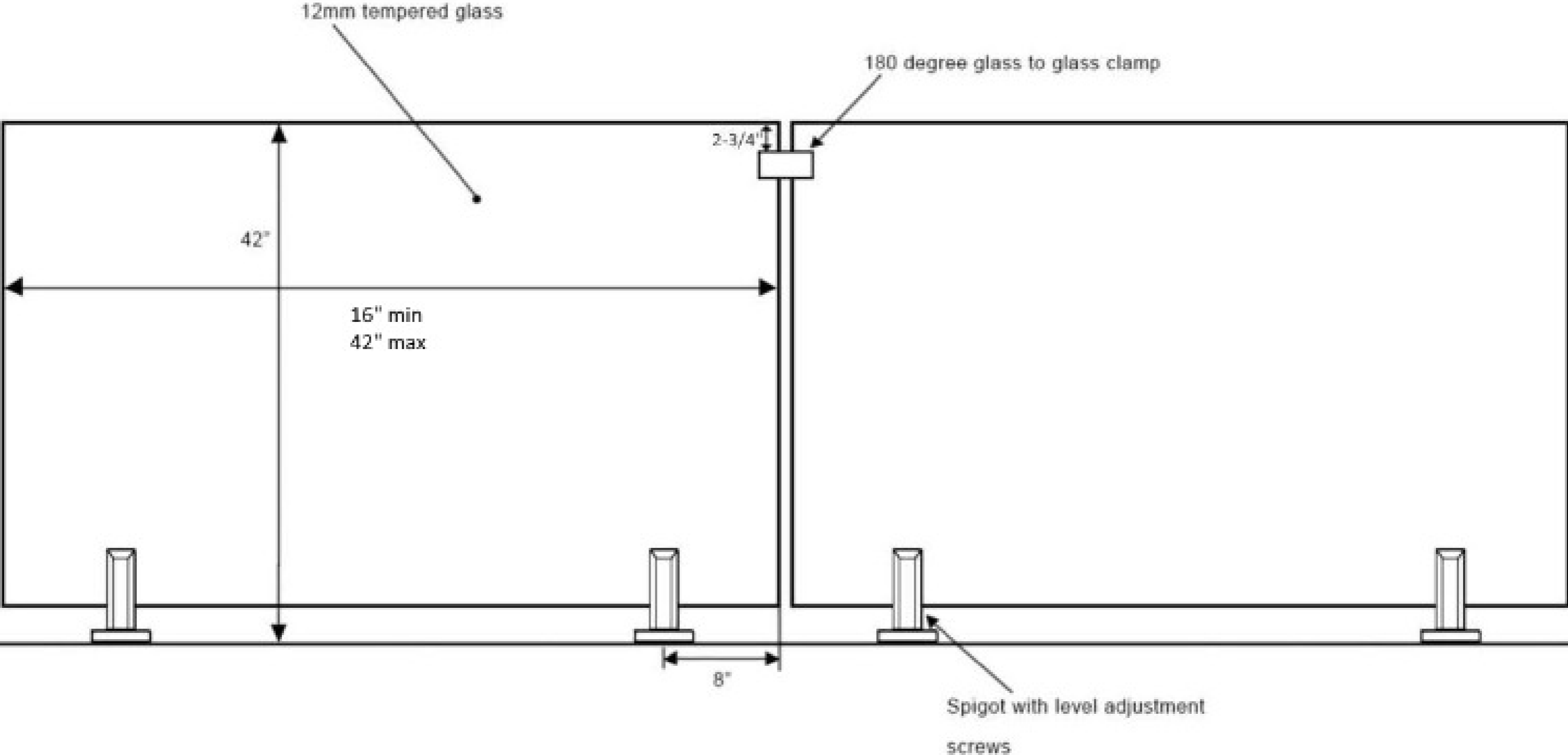

Appendix C
Confidential Drawings
(3 pages)

Components

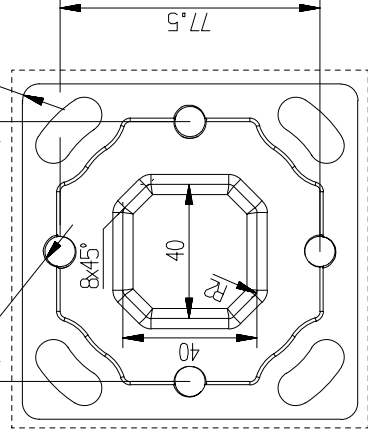
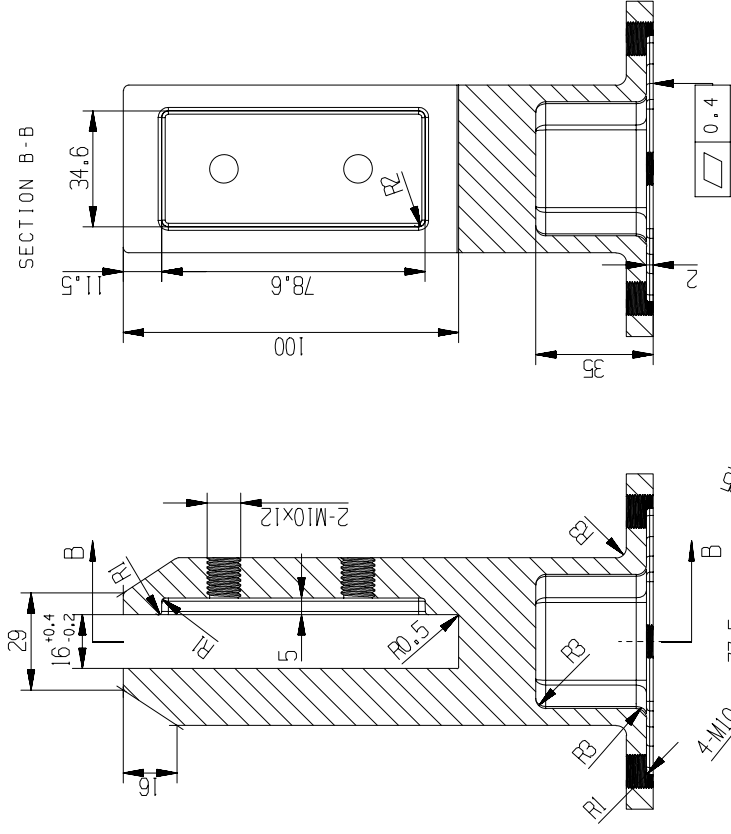
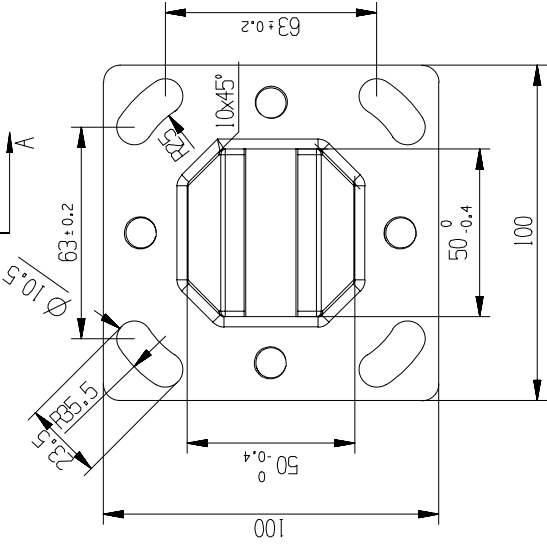
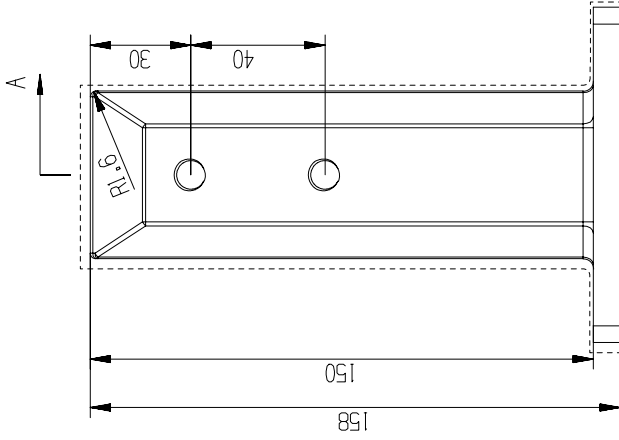
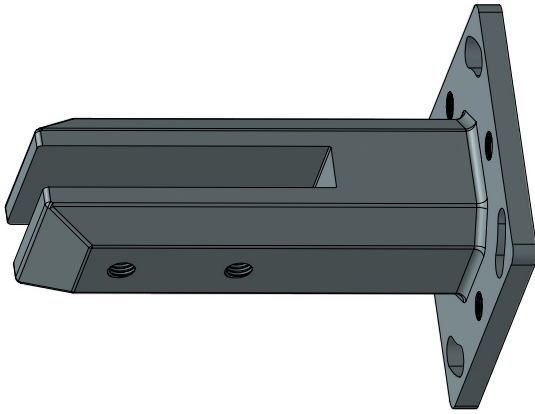

Material : Stainless Steel 2205
 Scale: 1: 1.5
 Name : Spigot With Level Adjustment
 Screws

Components cont.

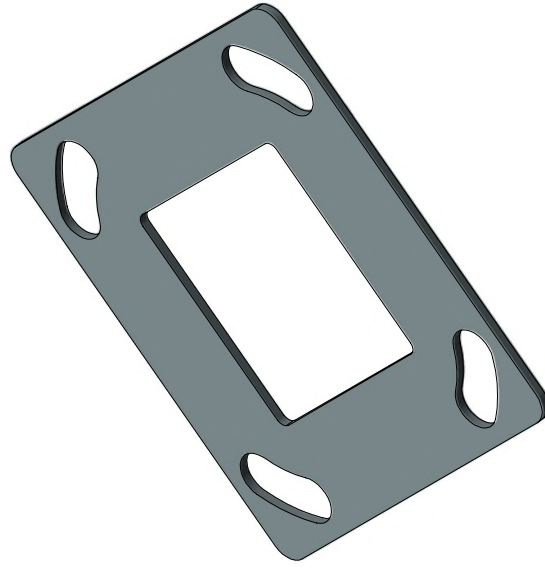
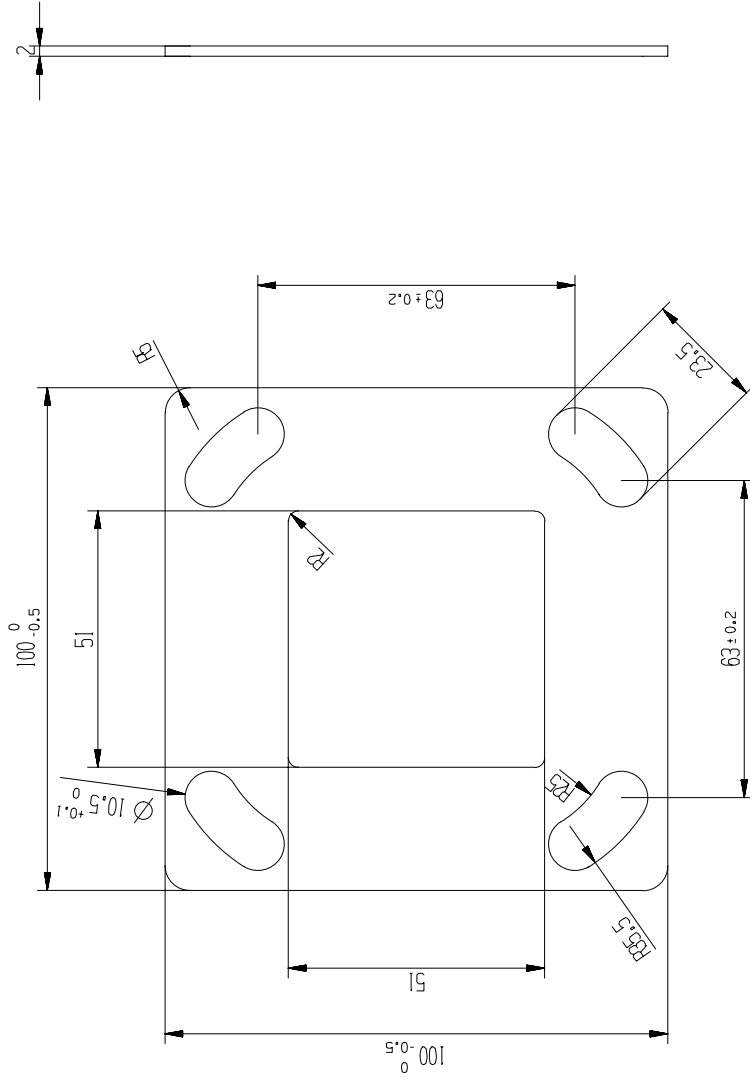

Material : Stainless Steel 316

Scale: 1 : 1.5

Name : Base Plate

Components cont.

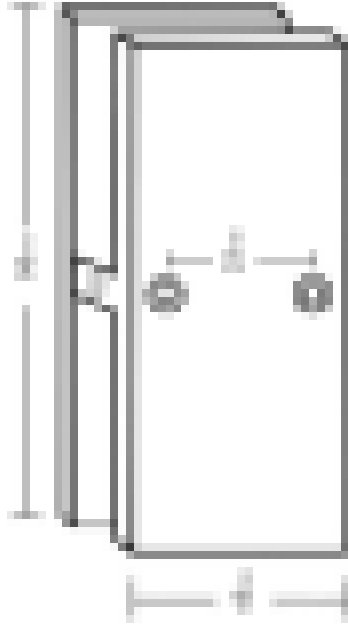

Material : Stainless Steel 316

Scale: 1: 1.5

Name: 180° Square Glass-to-Glass Railing
Clamp